

# WILD ONE



## INDEPENDENCE

### WILD ONE SKELETON 42MM GREY

#### Reference:

NNQ3000QGB1AS/B018/3W1BR.20GQ - Price on black mesh rubber strap grey buckle

EUR 5'250

The Wild ONE, made with our proprietary, ultra-robust and ultra-light grey NORTEQ® carbon fibre material, is the ultimate high-performance sports watch. Six times lighter than steel and 3.5 times lighter than titanium this Wild ONE has been designed in collaboration with Jean-Claude Biver, the NORQAIN team and the best Swiss suppliers.

#### MOVEMENT

NORQAIN Calibre NB08S

Mechanical automatic skeleton movement

Chronometer certified (COSC)

26 rubies

Personalised NORQAIN oscillating weight

41 hours power reserve

Balance frequency: 28'800 vibrations per hour (4Hz)

#### DIAL & HANDS

Openworked black dial with white printings

White NORQAIN logo

Diamond-cut flat skeleton black plated indexes, with white X1 Super-LumiNova® spots

Diamond-cut faceted hour and minute hands, black plated, white X1 Super-LumiNova®-filled tip

Diamond-cut flat second hand, black plated, white X1 Super-LumiNova®-filled tip

#### CASE

Grey NORTEQ® cage (top and bottom parts)

Black rubber shock absorber

Sandblasted titanium container

Diameter: 42mm

Thickness: 12.30mm

Width between lugs: 22mm

Lug to lug: 49.40mm

Water resistance: 200m

Screw-down crown, overmolded with black rubber and NORQAIN logo

Engraved grey NORTEQ® NORQAIN plate on the left side of the case

#### GLASS & CASE BACK

Double anti-reflective, scratch-proof, sapphire glass

Open case back with scratch-proof sapphire glass

#### WARRANTY

2 + 1 year warranty (NORQAINER Community)



# WILD ONE

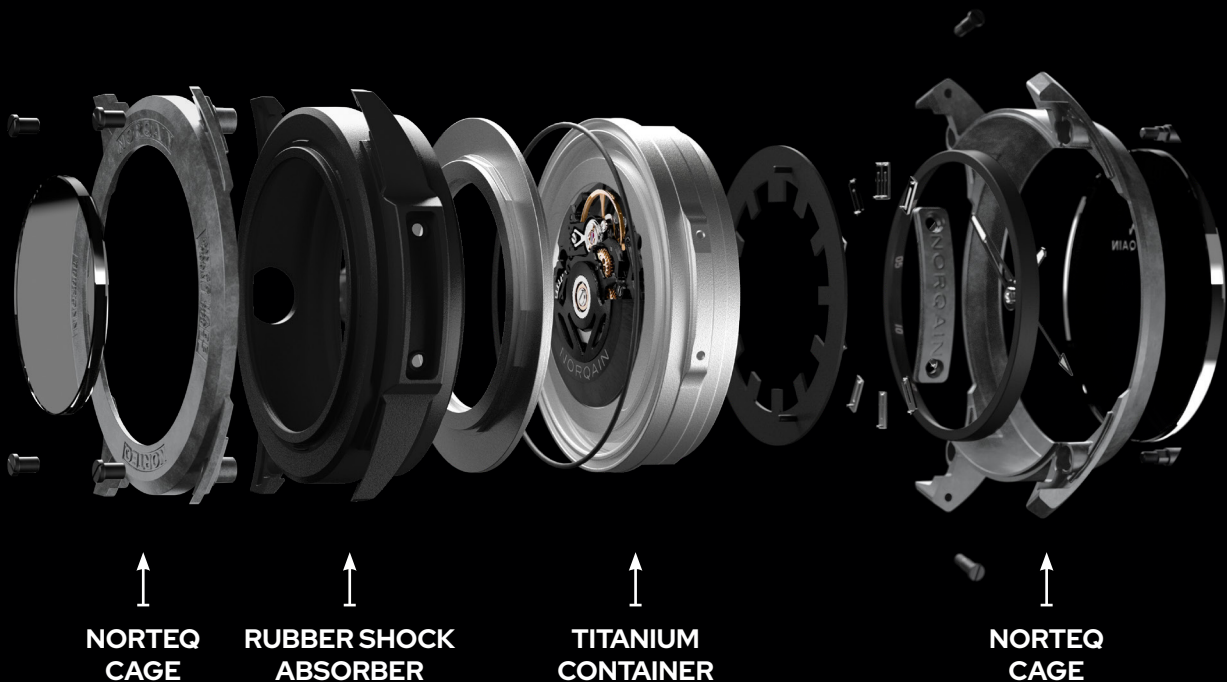

## WILD ONE

### THE ULTIMATE HIGH-PERFORMANCE SPORTS WATCH

- Revolutionary watch concept
- Watch case made of 25 parts
- Shock-absorbing construction
- Ultra robust: Withstanding 5000g (suitable for all kind of sport activities)
- Ultra light: 6.25 times lighter than steel / 3.5 times lighter than titanium
- World premier high-tech material
  - Carbon fibre composite made of carbon fibre and a high-performance polymer matrix containing 60% bio-sourced material (castor oil)
  - First brand to offer a mass-dyed carbon fibre composite case in any vivid colour other than black
  - Anti-magnetic and will not corrode over time
- Developed and designed together with industry legend and advisor to the NORQAIN board, Jean-Claude Biver
- Collaboration with premium Swiss suppliers in the industry
  - BIWI SA (design, concept and material)
  - Sellita (Skeleton movement)
  - Montremo SA (Openworked dial)
  - Waeber HMS SA (skeletonised hands)
  - MRP SA (case assembly and container production)

